

JKU | Department of Particulate Flow Modelling

JKU DEPARTMENT OF PARTICULATE FLOW MODELLING

T +43 (0)732/2468 6477 | **F** +43 (0)732/2468 6462 | **W** <http://www.particulate-flow.at>
P | Altenbergerstrasse 69, 4040 Linz, Austria

Front cover: Snap shot of an experiment on oil entrapment during bubble stirring in a water filled vessel showing the instantaneous velocity field together with the air bubble plume (white) and entrained oil droplets (green). In acquiring these multi-scale and multiphase experimental data three synchronized cameras with different filters were used together with two lasers. Complex simulations require complex experimental validation. ©B. König & S. Putteringer

EDITORIAL

Dear Readers,

2015 our Christian-Doppler Laboratory on Particulate Flow Modelling came to its end. In the past seven years we built up a strong research group, experiencing worldwide recognition.

For the future we are well prepared: with our JKU Department we settled in our academic home, together with industrial partners we started a competence center for applied research, we participate in two major European projects and finally, Simon Schneiderbauer succeeded in applying for a new CD-Lab on Multi-scale Simulation of Multiphase Flows – what a great perspective!

On a scientific level we focus on three core topics which all address the multi-scale nature of particulate processes. First, we develop an embedded simulation concept, nesting small-scale co-simulations into global ones. Next, we explore the possibilities of hybrid simulations, combining the worlds of continuous and discrete representation of dispersed matter and finally, we embark on a completely new research endeavor, which we baptized recurrence CFD. In this approach we try to time extrapolate offline simulations by statistical methods, bridging the worlds of CFD and process control.

With these introducing words I wish you a pleasant reading!

Sincerely,



Dear Readers,

Our K1-MET competence center is a handshake between industry and academia. From academic perspective K1-MET is the door towards industrial application.

After an international evaluation process K1-MET started operation in August 2015. Being fueled by contributions of major industries, governmental funding and academic contributions it covers the needs of both worlds – industries and universities.

Our Department has been strongly engaged in the definition of K1-MET, in particular in shaping Area-4, which is dedicated to numerical simulations. Here, we installed a GitHub simulation platform, which serves as a well defined link between researchers developing new simulation models and engineers applying them to real world problems. In addition to scientific/technical features this interlinking platform provides training, regular testing and a critical mass of smart employees, who are capable of performing project based short term simulations.

On a wider perspective we aim to share model development of this platform with partner universities, creating an academic simulation platform on European level.

With these introducing words we wish you a pleasant reading!

Sincerely,

Gijsbert Wierink
Area-4 Manager

Stefan Pirker
Area-4 Key
Researcher



CONTENTS

ROCK 'N' ROLL

Coupling different levels of resolution in DEM simulations	6
New Developments in LIGGGHTS	8
Cohesive material investigations	10
Erosion Onset in River Beds	12
Neural Networks for Particles Modelling	14

DUST 'N' DIRT

Multi-scale simulation of primary breakup of liquid jets	18
Two-Phase Flow Simulation	20
Modelling of Emulsion in Stirred Tank Reactor	22
Recurrence CFD	24
Flotation Modelling	26
Vacuum Degassing & Decarburization	28
Micropellet Technology	30

EXPERIMENTS

Bubble stirred flows	34
Particulate flow under centrifugal force	36
Blast Furnace Raceway Measurements and Data Analysis	38
Closed loop dust recycling	40
Particle Movement in a reduction shaft	42
Electrical Capacitance Tomography	44

SCIENTIFIC FRIENDS	46-48
---------------------------------	-------

SEMINAR

Aerosols Dispersion.....	50
--------------------------	----

SELECTED PUBLICATIONS	52
------------------------------------	----

EDITORIAL | ROCK 'N' ROLL

Dear Readers,

It is a pleasure for me to write these lines since it is my first opportunity to address you in our brochure after I joined our department one year ago to lead the R'n'R group.

According to these circumstances, 2015 was a year of transformation and reorganization for my subdivision. However, in the course of renewal we are cautious neither to forget our solid base nor our aim. Our research focus has shifted more towards multi-scale **modelling** of granular flows, but nevertheless we rely on and keep extending our stable software framework to develop and test our models for one purpose: simulating industrial-scale particulate flows based on their discrete constituents.

In this challenging quest, many people are involved with widespread tasks. With **Richard Berger**, who has substantially improved code quality of LIGGGHTS, and **Daniel Schiochet Nasato**, who has studied the filling processes of cohesive powders, two members of our group are finishing their PhD projects by the end of 2015. On the other hand, our newest member **Mathias Vångö** just joined us in September to investigate particles in multiphase flows.

Looking ahead towards 2016, current projects will be continued, new projects will be started, and I thank each member of my team for the passion and the hard work I know we will devote to all of them!

Sincerely,

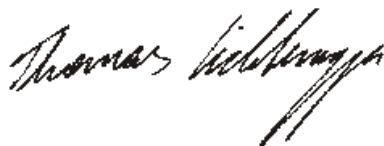

Thomas Lichtenegger | thomas.lichtenegger@jku.at

EDITORIAL | ROCK 'N' ROLL

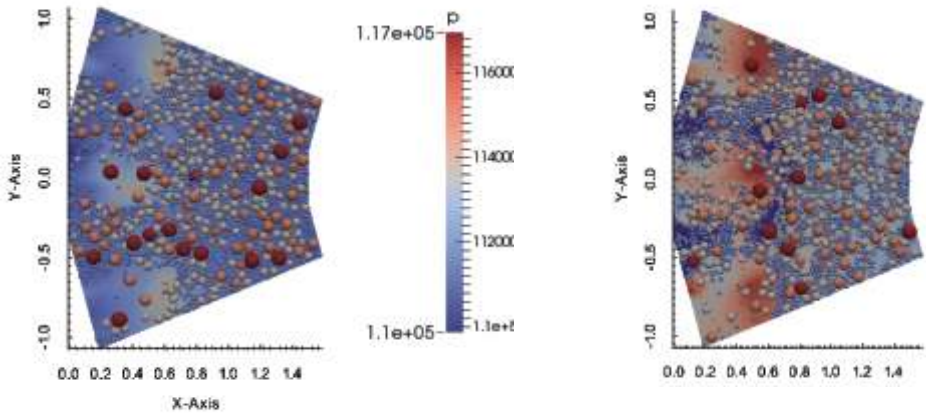

Fig.1: Blast furnace simulation, cut through raceway plane. The influence of small fragments (right figure) on the pressure profile in the raceway region (background color) is studied in comparison to a case without fragments (left figure). The smallest particles tend to clog the bed in the raceway boundary, which leads to a pressure increase.

ROCK 'N' ROLL | COUPLING DIFFERENT LEVELS OF RESOLUTION IN DEM SIMULATIONS

Despite constantly growing computing power, discrete element method (DEM) simulations of particulate systems can hardly reach the time and length scales required to describe industrial applications.

Coarse-grained (cg) models have been developed to reduce computational costs and make simulations of large granular systems feasible. However, these models cannot replace fine-grained (fg) simulations completely. Important details may be missed and in the worst case incorrect results are produced.

We introduce a novel technique for efficient multi-scale DEM simulations. The approach is designed for granular systems where full resolution is required only in spatially confined sub-regions whereas a lower level of detail is sufficient for the rest of the system.

Our method establishes two-way coupling between fine- and coarse-grained parts of the system by volumetric passing of boundary conditions. By this we are able to reach large time and length scales while retaining details of critical regions.

The method can be tested by comparing the computed statistical properties of the coupled cg-fg model with the corresponding properties of the fully resolved reference system.

Figure 1 illustrates the approach with the example of an hourglass. The mass flow through the neck - and in further consequence the time measured by the hourglass - substantially depends on the ratio of particle size and the neck width. Thus, we can expect different behavior of the cg and fg simulations.

Indeed, we observe that the hourglass containing the cg particles becomes clogged at some point while the fg particles keep flowing to the last grain. We can overcome this problem by correcting the mass flow through the neck of the cg simulation by the data acquired from the fg sub-region and still require fewer particles than the reference system.

Figure 2 shows the grid used for averaging and coupling of particle properties in this case. Here, the top and bottom layers of cells are used to establish valid boundary conditions in the fg part while the cells in between are used to correct the cg part of the simulation.

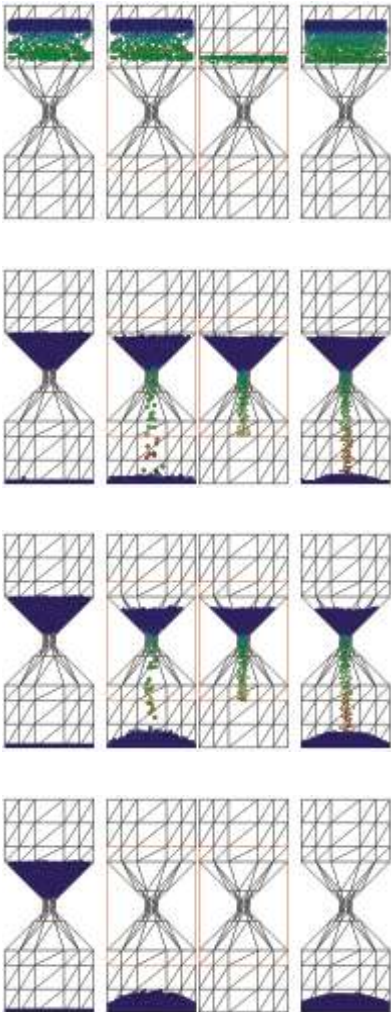
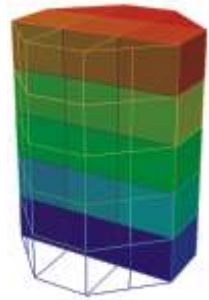

Fig.1: The cg simulation (left) cannot reproduce the behavior of its fg counterpart (right). Coupling to a fg sub-region (red) can correct this issue (middle).

(a)



(b)



Fig.2: (a) Grid used for averaging and coupling of granular properties. (b) Surface of the grid used to measure the mass flow into and out of the fg Sub-region.



ROCK 'N' ROLL | NEW DEVELOPMENTS IN LIGGGHTS

DEM simulations are limited by the total amount of particles in a simulation domain and their time step size. Small time steps are needed to resolve all particle collisions, avoid the introduction of non-physical kinetic energy and ensure stable and realistic simulations. This year two new approaches have been explored in LIGGGHTS to help mitigate the existing limitations.

Dynamic Particle Freezing

LIGGGHTS can now dynamically freeze and unfreeze particles based on their activity. Simulations which contain areas of inactive particle regions can benefit from this new feature.

A test case for this type of simulation is the filling of a silo as seen in Fig. 1. As granular media is poured into the domain particles at the base of the silo eventually come to rest and form a packed bed. Once in this state, the average position of these particles will not change. By specifying a cut-off for kinetic energy and its gradient these resting particles can be frozen in space and ignored for further time integration. Waves of activity beyond the given threshold dynamically unfreeze particles which allows changes to propagate through the domain.

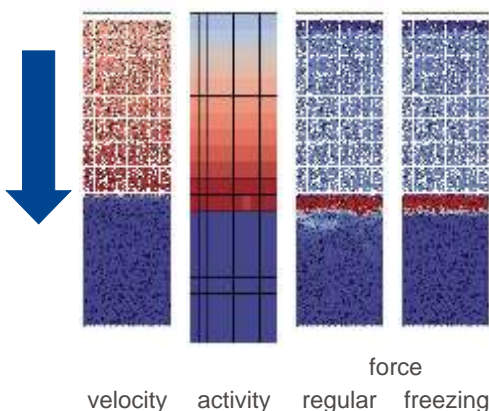

Fig.1: Particle Freezing in Silo Filling Example

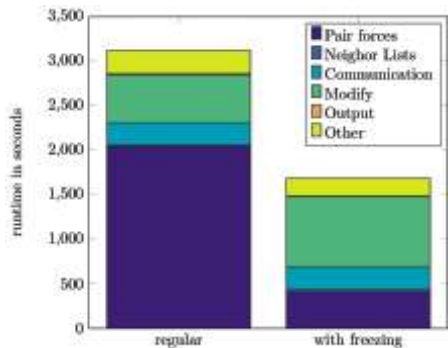

Fig.2: Speedup due to freezing in a Silo Filling Simulation with 50,000 particles

This can reduce the total computational cost of such a simulation, especially in the setup phase to generate an initial setting. Figure 2 illustrates the speedup obtained of using particle freezing in silo filling example. It shows how the amount of pair force computation was reduced, since the simulation focuses on active particles only at the top of the particle bed. While the detection of activity adds an overhead to the total computation it, the benefit of less force computations and integration pays off.

Multiple Time-Stepping

Another approach investigated was adding support of multiple time steps in LIGGGHTS. Regions of less interest should be simulated with larger time steps, while important regions are resolved in full temporal resolution (see Fig.3).

The feasibility of this approach was investigated with a prototype which supports multiple subsystems and uses an adapted integrator. Each subsystem can operate in different time-steps inside of the same simulation.

This approach was found to be limited by its added implementation overhead. To maintain physically meaningful results further investigation and the development of dynamic coarse graining in areas with higher time steps will be needed.

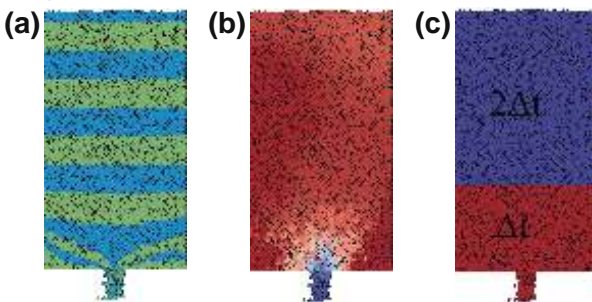

Fig.3: (a) Silo Discharge Simulation, with differently colored layers to illustrate flow pattern (b) Coloring of particles which have to be computed with theoretical time step limit (blue) vs. particles which could be computed with double the time step (red) (c) Separation of simulation into two sub systems



ROCK 'N' ROLL | COHESIVE MATERIAL INVESTIGATIONS

Simulation of die filling process and material variables

The powder flow behaviour during die filling is governed by a combination of factors. Powder characteristics like particle size, and surface properties as well as operating conditions such as die shape and vibration affect the final density distribution of our powder. Cohesion in powders may create cavities which lead to inhomogeneties. We created cavities experimentally (Fig.1) and through numerical simulations studied their collapse (Fig.2). Geometrical aspects of a cylindrical die, cohesiveness and pouring recipes were studied using for different shaking modes (Fig. 3) by means of tracking void fraction variation with time in different regions of the die (Fig.4). Dependencies of the process variables and material properties in die filling were depicted.



Fig.1: Creation of cavities in sand sample by adding water. Left dry sample and right wet sample.

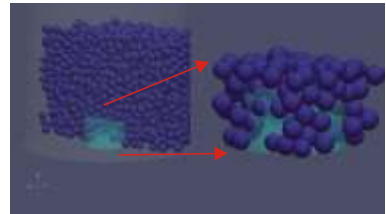

Fig.2: Numerical study of cavity. Created cavity in details.

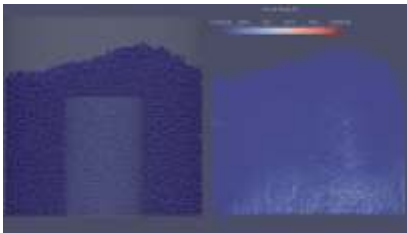

Fig.3: Die with internal (left). On the right details of the force chains.

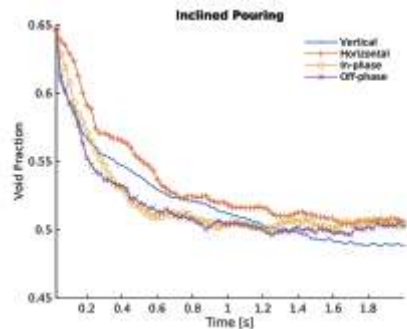

Fig.4: Void fraction (y axis) variation with time for different shaking modes. Case using an inclined pouring and internals.

Cohesive material flow in a increased gravity environment

Mass flow in hopper discharge is an extensively studied topic and Beverloo equation is maybe the most famous correlation to predict discharge rate. We investigate the effects of increased gravity and cohesion in a flat bottom hopper flow rate. We observe numerically the effect of increased gravity in Beverloo predictions and the effect of cohesive forces in the mass flow. A no-flow condition for low centrifugal forces and highly cohesive material is observed (Fig.5). Increasing centrifugal force makes same cohesive material starts flowing. It shows a similar behaviour to Beverloo predictions although shifted in absolute values. Results will help us understand the effect of increased gravity and cohesion in mass flow. A centrifuge was assembled to validate our numerical predictions.

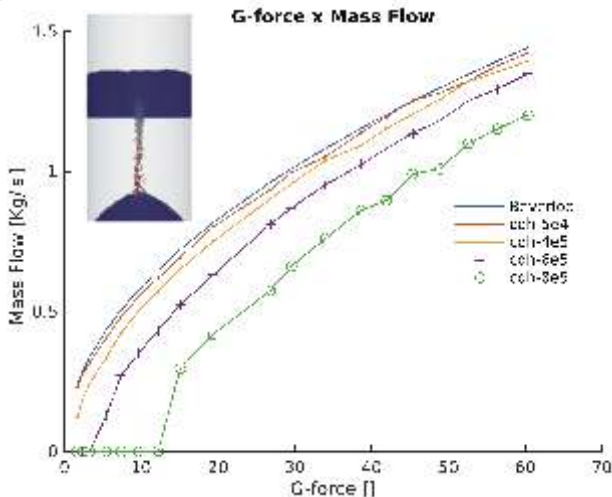

Fig.5: Predictions of Beverloo equation and numerical simulations for increased centrifugal forces. For higher cohesive forces (green line) a no-flow condition up to 12g is observed. For higher accelerations we depict a mass flow with similar behaviour to Beverloo although shifted in absolute values of mass flow



Supervision:
Stefan Pirker

Daniel Schiochet Nasato | daniel.schiochet_nasato@jku.at

ROCK 'N' ROLL | EROSION ONSET IN RIVER BEDS

Sediment transport in river beds is an interesting topic from both an ecologic and economic point of view. However, it is a multi-scale problem and thus hard to model: The river is usually at least several meters wide, while the typical sediment size is in the centimeter or even millimeter range. Thus, fully resolving the sediment scale would require very fine meshes and in consequence prohibitively high computational effort. To get around this problem, we are aiming at a coupled multi-scale approach where a small-scale LBDEM simulation is linked to a large-scale FV simulation of the whole river (Fig.1a, 1b).

As a first step, we validated a small-scale simulation. A bed of particles was created in a cubic box, and turbulent shear flow over this bed was imposed. Albert Shields [1] showed that the onset of bed movement for a bed of particles with diameter d_p and density ρ_p is governed by two parameters: The dimensionless shear stress $\Theta = \frac{\tau_0}{\rho_f g d_p}$ and the friction Reynolds number $Re_f = \frac{u_f d_p}{\nu}$ with the friction velocity $u_f = \sqrt{\tau_0 / \rho_f}$. For each Re_f , Shields experimentally determined a critical dimensionless shear stress Θ_0 above which bed movement is expected. This is known as the Shields curve.

We conducted simulations with different friction Reynolds numbers and used the total momentum of the particles to evaluate whether the bed moved or not. For the cases considered, we found good agreement with the Shields curve (see Fig.2). We also conducted simulations with a bed of ellipsoids and a bidisperse bed. For the former, we found constant, but lower total particle momentum as for a bed of spheres at the same Re_f , while for the latter a sudden drop in momentum was found. This hints at segregation phenomena in the bed (see Fig.3).

Our next goal is the realization of a coupled simulation where an unsteady flow field obtained by a global FV simulation is imposed on the small-scale simulation. The coupling methodology is intended to be kept generic, so it can be applied to other multi-scale problems.

References:

[1] Albert Shields. Anwendung der Ähnlichkeitsmechanik und der Turbulenzforschung auf die Geschiebebewegung. Preussische Versuchsanstalt für Wasserbau, 1936.

[2] Keylock et al., Geomorphology 179 (2012): 1-20

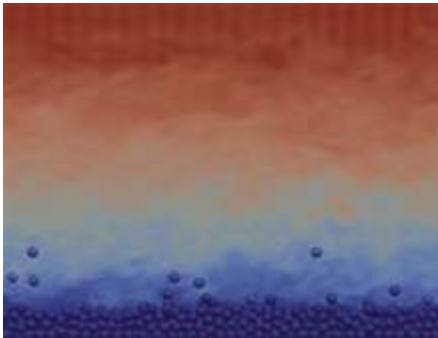

Fig.1a(left): Small-scale simulation: Spheres in a turbulent shear flow.

Fig.1b(below): Schematic of a large-scale simulation where an LBDEM simulation could be embedded. Image source: [2]

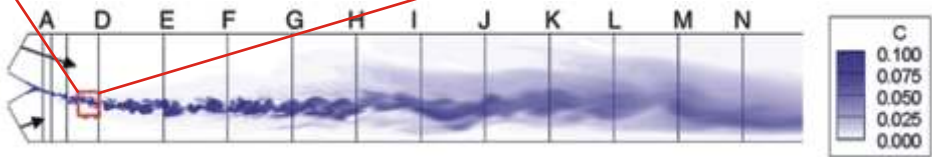

Fig.2(left): Large graph: particle momentum over time for four Re_f . Small graph: Location of these four cases in the Shields diagram, blue line: Shields curve.

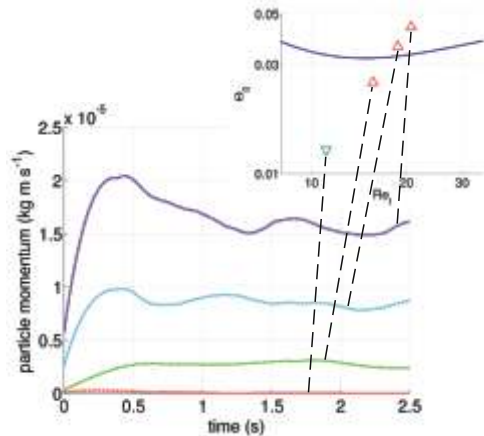
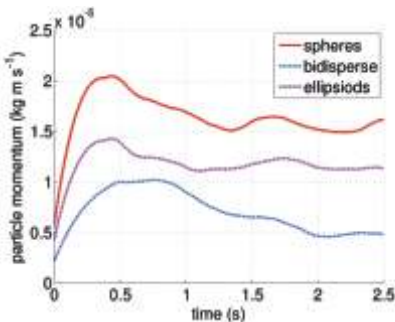

Fig.3(below): Momentum over time for spheres (red, full), ellipsoids (pink, dashed), and a bidisperse mixture (blue, dash-dotted). Drop of momentum at 1.5s for the bidisperse mixture hints at segregation phenomena.



ROCK 'N' ROLL | NEURAL NETWORKS FOR PARTICLE MODELLING

Many materials are granular in nature: for instance, gravel, corn seeds, pharmaceutical powders, sands and ores.

The behaviour of these materials in industrial and mining processes can be efficiently picture by Discrete Element Method (DEM) simulations. However, to define the microscopic properties of the granular particles a characterization procedure is necessary. This usually consists of comparing experimental macroscopic results from standardized experiments with numerical simulations of the same devices (e.g., shear cell, angle of repose). Thus, this solution is exceedingly computationally expensive for many raw materials. In fact, the macroscopic numerical behaviour is defined by many microscopic parameters, which lead the amount of numerical simulations necessary to ascertain them to extraordinary heights.

Parameter Identification

To deal with the problem, we used a innovative statistical approach, the artificial neural networks (Fig.1 and 2). We managed to evaluate the sensitivity of the bulk behavior with respect to individual particle based parameters. Inside the neural networks (NN) neurons are linked to particle based input parameters. By matching the output of the artificial neural network to DEM simulation results the network is trained (i.e. individual neurons are weighted), with excellent regression results.



Fig.1: Biological inspiration
[www.extremetech.com]

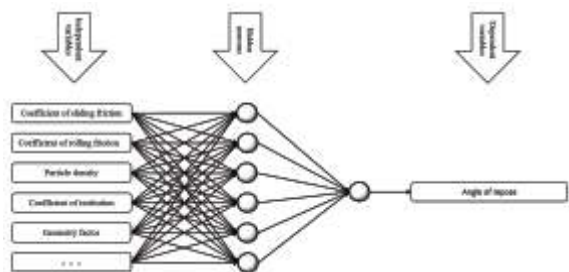

Fig.2: Neural Network Architecture

Later, the trained neural network can be used to predict additional valid sets of particle based simulation parameters: we compare the macro-bulk behavior of these sets against the experimental data collected, gaining averages and validity range (see the box plot in Fig.3).

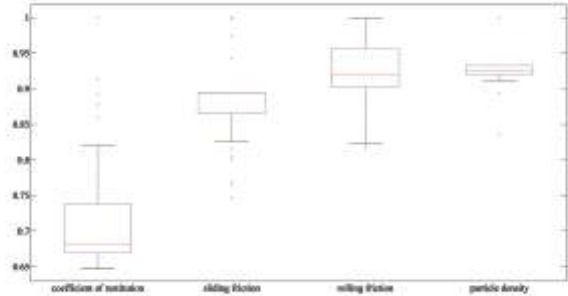

Fig.3: Box plot of the validity ranges for the parameters.

Applications

When the microscopic properties of the particles are defined, this data are used in large scale DEM simulations of industrial processes. We investigated the effect of the friction coefficients on the diameter of the raceway in a blast furnace (Fig.4). Further, the calibrated parameters proved the segregations capabilities of a patented sinter cooler chute (Fig.5).

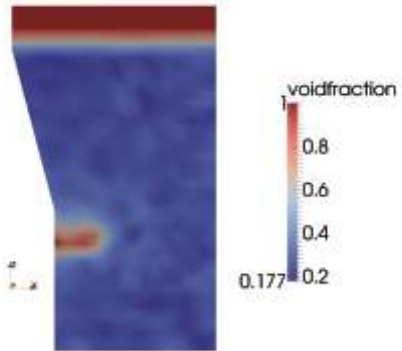

Fig.4: Raceway formation

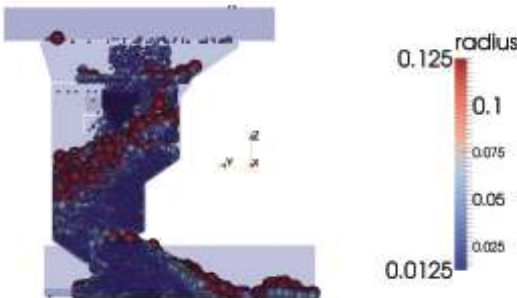

Fig.5: Sinter cooler



EDITORIAL | DUST 'N' DIRT

Dear Readers,

First I want to officially welcome our new PhD **Reza Farzad**. Reza will work on the numerical simulation of stirred tank reactors, which are of primary importance in chemical industries. His numerical activities are supported by experimental studies on droplet breakup in external flows (Fig.1) as well as analytical considerations, which corresponds to our successful threefold investigation approach.

Furthermore, I want to congratulate Mahdi Saeedipour, who received the "Paul Eisenklam Travel Award for young researchers", which is awarded to excellent students in the field of Liquid Atomization and Spray Systems.

The year 2015 was additionally a year, which brought the continuum models closer to industrial applications. For example, firstly Afsaneh Soleimani was able to further verify her pneumatic conveying model (Fig.2) and to propose significant optimizations of industrial conveying lines. Secondly, our hybrid model for fluidized beds was successfully applied to industrial scale fluidized beds allowing, for example, the optimization of the spout grid arrangement of the distributor plate.

With this in mind, I am looking forward to 2016, where I hopefully get the opportunity to start my own CD-Laboratory. This CD-Laboratory will closely cooperate and complement the current research activities in the K1MET. Finally, I want to thank all my team members for their excellent work!

Sincerely,



EDITORIAL | DUST 'N' DIRT



Fig.1: Formation of an oil/water emulsion in a Couette flow device

Fig.2: Particle concentration in the elbow mid-plane: a) two-way coupling (Lain and Sommerfeld, 2014); b) four-way coupling (Lain and Sommerfeld (2014)); c) two-fluid model (including wall-roughness and particles turbulence effect in model)

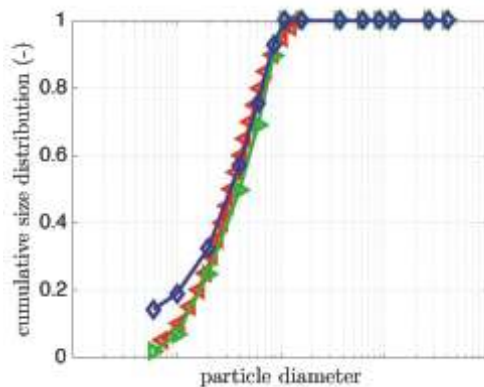

Fig.3: Particle size distribution of the offgas of an industrial scale cyclone. Red: experiment; blue: w/o agglomeration; green: w/ agglomeration

DUST 'N' DIRT

MULTI-SCALE SIMULATION OF PRIMARY BREAKUP OF LIQUID JETS

Fluid instabilities near liquid-gas interface may result in disintegration and breakup as well as influencing the dynamic behavior of the flow in most industrial applications such as fuel injection, spray cooling, fire fighting systems and medical sprays. In addition, liquid jet instabilities leading to breakup plays an integral role in liquid metal and manufacturing industries such as high pressure die casting (HPDC).

Most fluid flows in above applications involve multiscale phenomena. Small scale flow events can considerably affect the macroscopic behavior of a flow configuration. In other words, micro-scale turbulent eddies are responsible for the instability of free surface and consequently disintegration of the liquid jet. For instance, in HPDC process, the disintegration of liquid jet will lead to formation of small scale molten metal droplets prone to impinge the confining mold walls. According to the dynamics of the droplets, the frequency of droplet impingement and the solidification time scale, this may result in porosity formation in the final product. Therefore the fluid instability and jet disintegration can control and affect the process parameters.

Although there has been a huge effort on the numerical modelling of liquid jet breakup resulting in different modelling approaches, the appropriate choice of modeling strategy may still vary from one problem to the other. In this research, a multiscale model for the coarse-grid simulation of turbulent liquid jet breakup using an Eulerian-Lagrangian coupling. In this multiscale approach, a numerical simulation using volume of fluid method (VOF) is carried out to model the global (meso-scale) spreading of liquid jet. The formation of the micro-scale droplets which are usually smaller than the grid spacing in computational domain is determined by a surface energy-based sub-grid model (Fig.1). So far, the presented methodology was tested for different liquid jets in Rayleigh, wind-induced and atomization regimes and validated against literature data (Fig.2). We have planned to do more sophisticated validations by performing experiments using Phase Doppler system (PDA) within the final steps of this research.

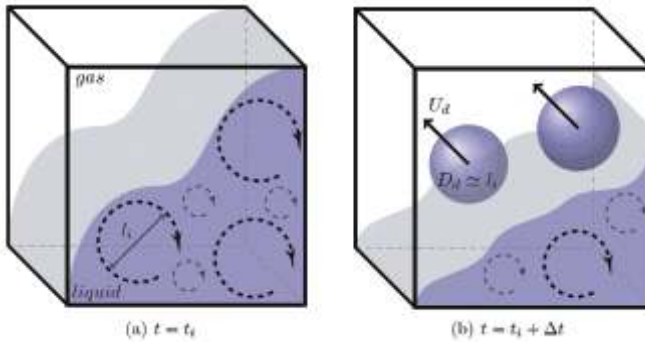

Fig.1: Schematic of sub-grid breakup model and Eulerian - Lagrangian coupling. Droplets are extracted along with the interface.

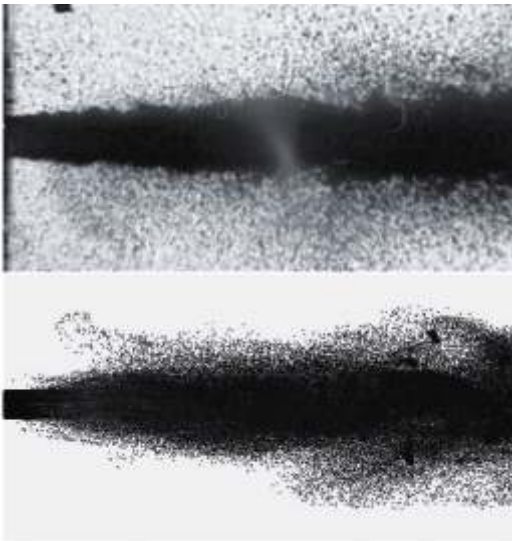

Fig.2: Simulation results for ethanol jet with $U = 20$ m/s at $P=6$ MPa after 5 ms (bottom) compared with experiments by Mayer and Branam (2004) (top).



DUST 'N' DIRT | TWO-PHASE FLOW SIMULATION

Transport of powder materials, which is an important part of many industrial processes, can be affected by several factors. Wall-friction and wall-roughness are two important factors, which strongly affect the movement of the solid particles, especially within confined flows such as pneumatic conveying lines. Accordingly, in the first one and a half years, a complete model for boundary conditions in Eulerian frame-work was introduced (Solid boundary condition for collisional gas-solid flows at rough walls; Soleymani A. et al, 2015) and implemented in the standard solver of OpenFOAM. The implemented boundary conditions account for the effect of wall friction as well as wall roughness in a wall-bounded flow. The turbulence model and gas-particle interaction are the other aspects, which were investigated. By implementing interaction coupling terms we accounted for the effect of particles in gas turbulence. However, beside the boundary condition modelling and turbulent gas-particle interaction, the geometry of the conveying lines and the optimization of them also play a substantial role in the system operation.

- A more complex geometry based on the industrial application was simulated as a next step (Fig.1).

The time averaged out-flow rate of particles for 20 different outlets were compared. The results show that the out-flow rate increases from lower level to the upper level of distributors with a difference about 50% between the maximum and minimum out-flow rate. Furthermore, the results show the frequent fluctuation of out-flow rate, which is decreased in the plot by time averaging (Fig.2).

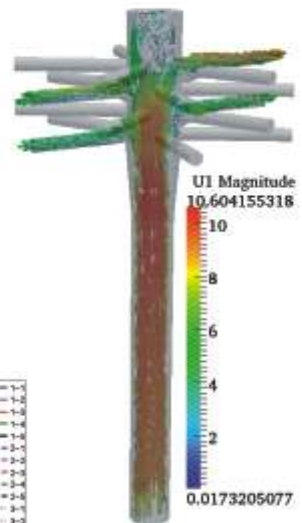

Fig.1: Particles velocity at a mid-plane of outlets

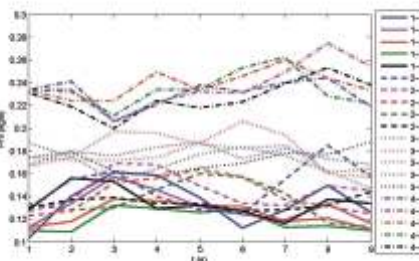

Fig.2: Time-Average out-flow rate of particles for different outlets

The different out-flow rates of the highest and lowest level of the outlets, lead to the different mass loading values of the injectors to various positions in the furnaces

- In order to optimize the geometry of the distributor yielding equally distributed Particle fluxes, we suggested a new geometry with more symmetric Layout of outlets (Fig.3).

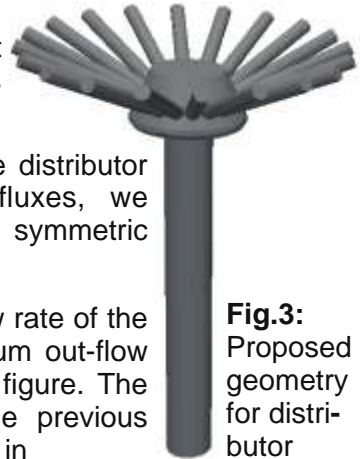

Fig.3: Proposed geometry for distributor

Figure 4 shows a comparison of the out-flow rate of the two geometries. The maximum and minimum out-flow rates of each geometry are plotted in this figure. The results show that the out-flow rate in the previous geometry has a more considerable fluctuation in comparison to the proposed geometry, which could be the results of asymmetry and associated velocity fluctuation. Furthermore, the comparison between two geometries reveals that the difference of out-flow rate between the maximum and minimum values is significantly decreased in the new proposed geometry, which leads to a more equivalent distribution of materials.

Fig.4: Comparison of max. and min. particles Out-flow for two different geometries. Blue and red solid lines: Min. of original and suggested geometries respectively. Violet and red dashed lines: the Max. of original and new geometry respectively.

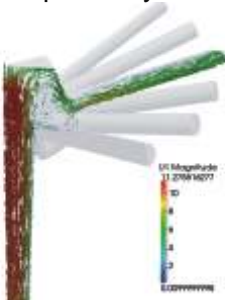
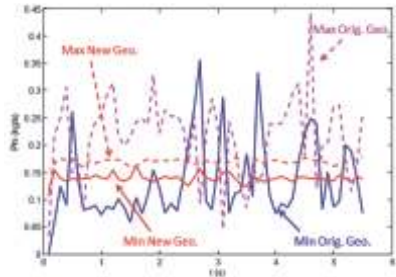

Fig.5: Particles velocity arrows at the mid-plane of an outlet



Supervision:
Schneiderbauer

Afsaneh Soleimani | afsaneh.soleimani@jku.at

DUST 'N' DIRT | MODELLING OF EMULSION IN STIRRED TANK REACTOR

Stirred tank reactors have a wide range of applications in process industries such as pharmaceutical, food, cosmetic, polymer and many other types of the chemical products. The mixing process is one of the main tasks of stirred tank reactors. Homogenization, increasing of heat transfer, solid-liquid mixing (suspension), liquid-liquid mixing (emulsion) and gas-liquid mixing (sparging) are the primary applications of mixing operation. Liquid-liquid mixing forming emulsions is the main focus of the current study.

The mixture of two immiscible liquids, where one of them is dispersed (dispersed phase) to another one remains continuous, is called emulsion. Emulsions can be found in our daily consumed products including food, medicine, cosmetic and polymers. Mayonnaise sauce is one of the most famous examples of emulsions.

The specific droplet size (dispersed phase) is the crucial issue in emulsions. Shear forces are playing an important role to provide disruptive energy of breakup. On the other hand, dispersed phase viscosity and interfacial tension prevent the droplet from breakup. Coalescence should be eliminated by using stabilizers (surfactants) to provide a stable emulsion.

Predicting the correct flow pattern and shear rate inside the stirred tank provides data concerning the relation between one (several) process parameter(s), like impellers' rotation speed, and the size distribution of the droplets. Computational fluid dynamic (CFD) is a useful tool that can predict these desirable insights.

Stirred tank mesh was created by using ICEM Fluent (Fig.1). ANSYS Fluent was used to simulate the case with k- and RSM turbulence models in the first phase of the project (Fig.2).



Fig.1: Stirred tank reactor mesh

In addition, experimental work is under progress in a couette flow device (Fig.3) in order to verify the suggested idea about the final setup. Moreover, simple setup was built to calculate the interfacial tension based on the “drop-volume” method (Fig.4).

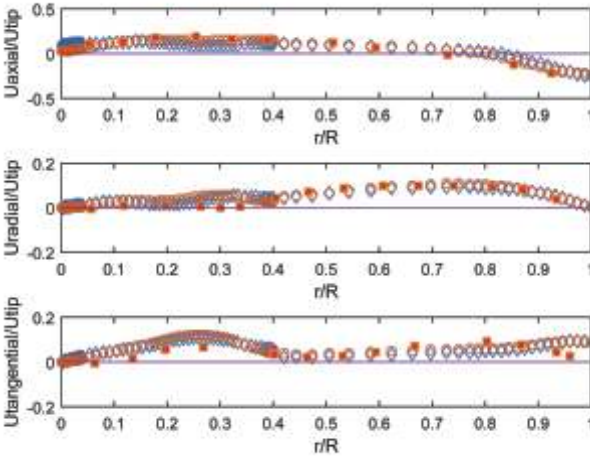

Fig.2: Non-dimensional velocity analysis at the height 0.082 cm from the tank’s bottom-Blue diamonds (k-e -simulation’s result), Red circles (RSM-simulation’s result) and red solid squares (experimental data of Murthy and Joshi, 2008)



Fig.4: Simple setup of the drop-volume method



Fig.3: Couette flow device, dispersed phase (oil) is dispersed in to the continues phase (distilled water) by rotation of inner cylinder



DUST 'N' DIRT | RECURRENCE CFD

Simulations of multiphase flows typically require very small time-steps and consequently, CFD simulations of industrial multiphase processes cost a lot of computational resources, especially if the process under consideration spans longer time periods. After years and years of expensive multiphase CFD simulations I asked myself if this degree of complexity is really necessary.

In unsteady flows we commonly observe recurring flow patterns. In the course of conventional CFD simulations we can identify such characteristic flow features and subsequently stitch them together to form a generic unsteady flow process by applying statistical reasoning and introducing a certain degree of randomness.

In Fig.1a a recurrence evaluation of a conventional CFD simulation of an oscillating bubble column is given. Based on this statistics the unsteady flow field has been proposed which serves as a base for the calculation of tracer distribution (also see Fig.1b). The tracer monitors in Fig.2 prove that the tracer distribution can be recovered by the generic flow field nearly perfectly. At the same time computational times are reduced dramatically by a factor of 400 so that the new recurrence CFD simulation performs in real-time! The results are so promising that we officially baptized this new methodology as **recurrence CFD = rCFD**.

Finally, Fig.3 depicts a snap shot of a **rCFD** simulation of iron-oxide reduction during post-stirring of a steelmaking converter. In this case a complex multiphase process (involving two liquid phases and gas bubbles) controls a heterogeneous reaction at the metal-slag interface. With **rCFD** this process can be simulated nearly two orders of magnitude faster than by conventional CFD, while delivering similar results at the same spatial resolution! From my perspective **rCFD** is a promising new methodology for efficient time extrapolation of numerical simulations.

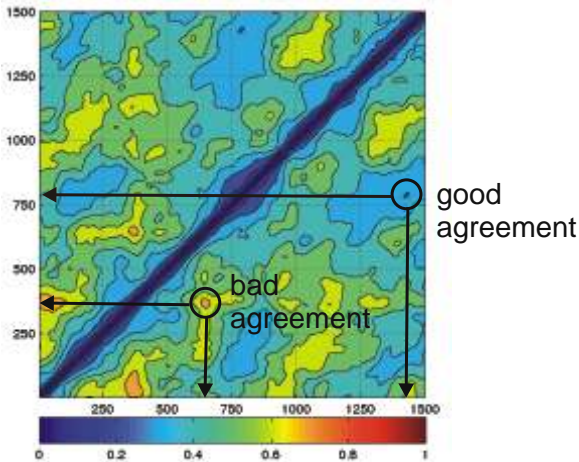

Fig.1: Recurrence plot (left) of a CFD simulation of an oscillating bubble column (right); in the right figure tracer probes are depicted

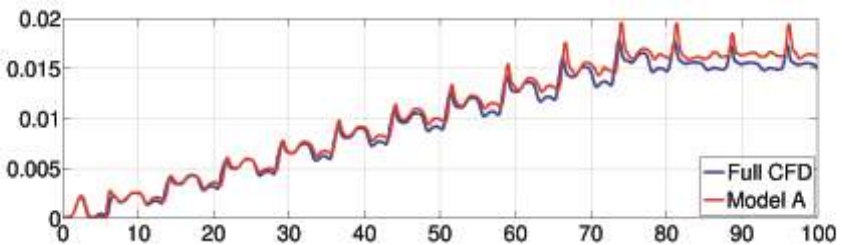

Fig.2: Comparison between full CFD and rCFD simulation of tracer dispersion at Probe-2.

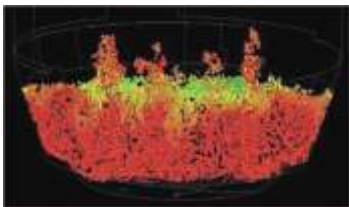

Fig.3: rCFD simulation of de-carbonization during post-stirring; colouring by carbon concentration

Gerhard Holzinger | Stefan Pirker



DUST 'N' DIRT | FLOTATION MODELLING

Flotation is a widely used separation process used in many industries, such as mineral processing, waste paper recycling and waste water treatment. Selectivity of separation is achieved by a difference in hydrophobicity of the involved materials, either naturally occurring or technically imposed by chemical pre-treatment. In mineral processing flotation is a vital operation in the production of many end-products, such as copper, as the grade of processed ores is ever decreasing.

The goal of this project is to implement a flotation model in the open source CFD framework of OpenFOAM[®]. We implemented the model in a modular fashion, enabling the selection of various sub-process models and allowing for an easy extension of the model library.

Our flotation model, coupled with multi-phase CFD, allows the user to investigate the internals of a flotation device and to study the influence of the flow on the flotation performance. As real flotation devices tend to have more complex geometries than depicted in Figure 2, applying CFD is often necessary for studying the flow within the device.

In the course over the last three to four years a large body of working knowledge on OpenFOAM has accumulated by either curiosity, error hunting or mere procrastination. A write-up of this collected knowledge has been made publicly available in autumn 2014 on <https://github.com/ParticulateFlow/OSSCAR-doc>.

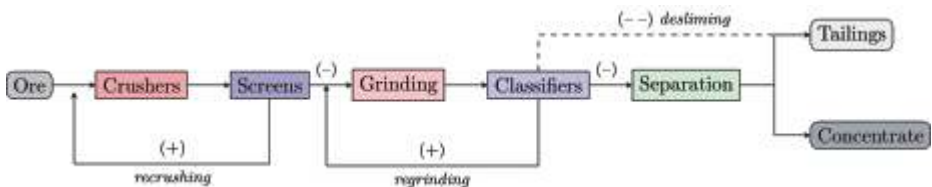

Fig.1: Flowchart of operations in a mineral processing plant. The (+) and (-) symbols indicate oversize and undersized materials. Flotation plants are part of the separation stage in this flowchart.

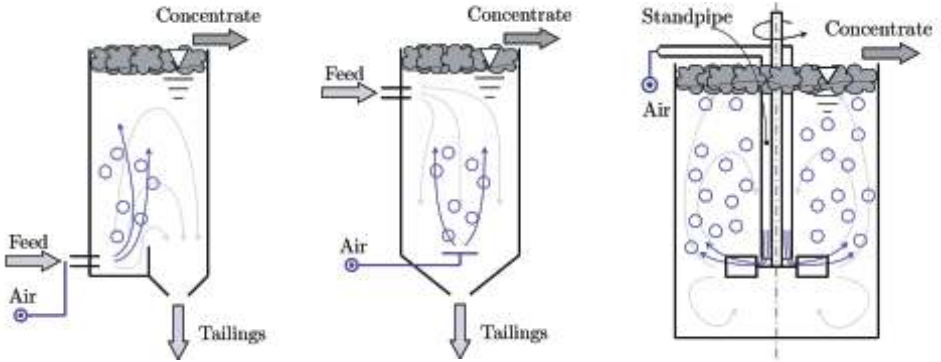

Fig.2: Schematic representation of pneumatic, column and mechanical flotation. The blue arrows indicate the flow of the air bubbles. The grey arrows indicate the slurry flow pattern.

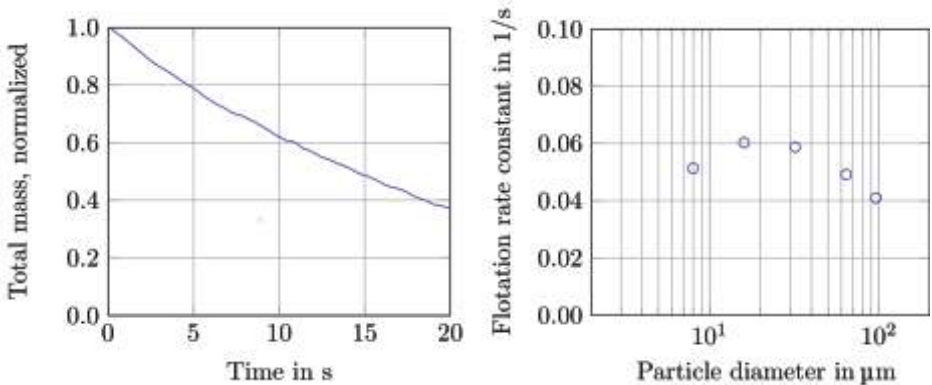

Fig.3: Results of a simulation of a simplified mechanical flotation cell with 5 particle size classes. Total concentration of floatable particles over time (left) and identified kinetic flotation rate over particle size (right).



DUST 'N' DIRT | VACUUM DEGASSING & DECARBURIZATION

Modern steel making processes can be categorized into:

- Primary steel making
- Secondary steel making

Vacuum degassing and decarburization form the major part of secondary steel making by which dissolved gases in the steel are lowered, inclusion are removed or altered to meet the quality demands of the customer.

Among various vacuum degassing systems, RH type degassers are the most popular. The RH Process (Fig.1) employs two legs on the vacuum chamber that are lowered into the melt. Argon is injected in one leg causing a vigorous bubbling and mixing action. RH process was initially introduced with the primary objective to reduce hydrogen content in the liquid steel. Application of the RH process for decarburization was introduced at the end of the 1970s. Today this technique is used to obtain extremely low final carbon contents of less than 20 ppm.

The RH process is based on the exchange of liquid steel between the steel ladle and the RH vessel. The rate of metallurgical reactions and the duration of the process to meet required steel composition is determined by the rate of steel recirculation. Liquid steel circulation depends on the geometry of the equipment, the position and number of lift gas tuyeres etc..

The present work on the topic aims at developing :

1. An analytical model (Fig.2) to analyze the influence of various factors like gas flow rate, shape and number of nozzles etc. on the rate of mass circulation and hence the decarburization/degassing efficiency.
2. A flow model by analyzing the small scale motions and turbulence effects using Large Eddy Simulation (LES) in OpenFOAM. The model is aimed to be validated with experimental results using water instead of steel and data from the steel plant.

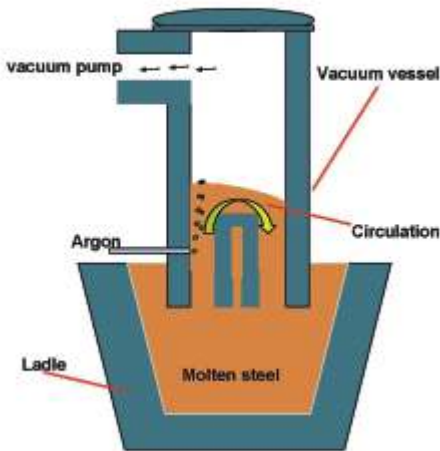

Fig.1 : Schematic Diagram RH plant for degassing and decarburization.

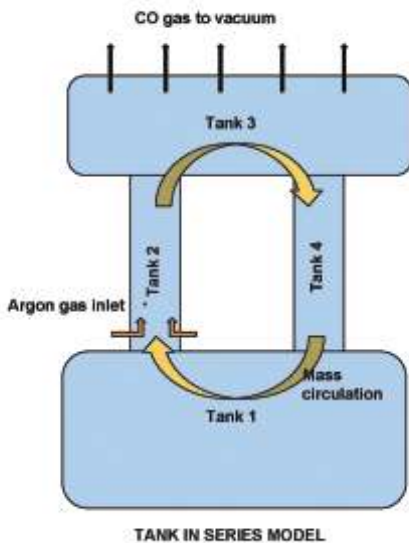

Fig.2: Stirred tank model Technique used for developing analytical model



DUST 'N' DIRT | MICROPELLET TECHNOLOGY

The granulation of plastics, especially thermoplastics, is an established process in the plastics processing industry. Typically, plastic granules are produced in a particle size range between 3 mm and 5 mm. Polyethylene (PE) is the world's most commonly processed plastics. Typical plastic pellets (PE, polypropylene – PP and polyamide – PA) cannot be used directly in rotomolding process. Due to the particle size, the melting would take too long and the form would be too inhomogeneous. Therefore, powdered plastics is used currently for this application, which must be manufactured by grinding of granules in advance. However, this is connected with a significant additional expense.

As an alternative to plastic powder in rotomolding, an underwater granulation technology for the production of PP micro-granules (diameter range of approx. 0.5mm) is developed in this project. The massive change in the hydrodynamic behaviour of micro-particles in the water flow compared to conventional granules gives the need of optimization of the housing geometry. For this, a series of numerical simulations has been conducted. These simulations involve fully three-dimensional moving meshes (rotating blades) combined with the instationary Lagrangian Discrete Phase Model (DPM). This means that plastic particles are created and their movement through the computational domain is calculated in Lagrangian reference frame. Particles enter the housing, they cool down in the water flow, and they collide with each other and with moving and stationary walls. The additional sub-models for adequate description of inter-particle collisions and particle-wall collisions are built in as well.

Plastic particles are scarped by the rotating blades as they enter the granulating housing, Fig. 1. Water flows through the housing and ensures the removal of particles. The local flow conditions in the housing are responsible for the particle transport. Unfavourable flow conditions may cause a local particles accumulation in the housing. Several particles can stick together and cause the failure of the granulation process.

One of the critical areas for the accumulation of particles is located in the middle of the front plate, Fig. 2 (left). Through improvement measures the number of particles in this area is significantly decreased, Fig. 2 (right).

This project is initiated by the ECON Company and supported by the Austrian Research Promotion Agency (FFG). Their support has been gratefully acknowledged.

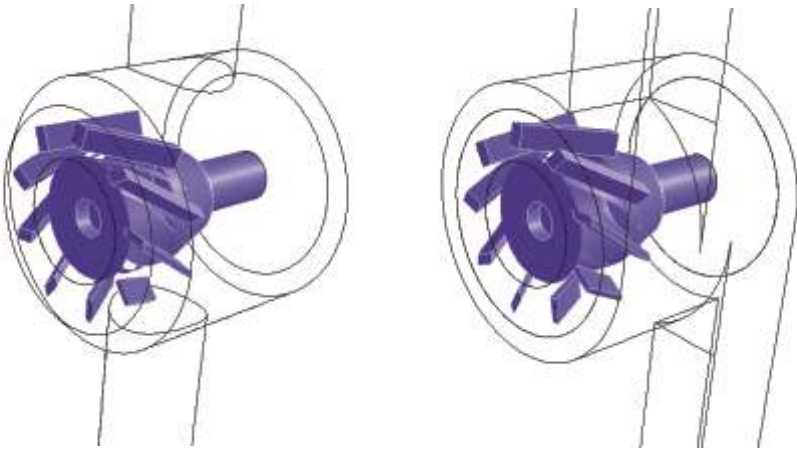

Fig.1: Housing geometries with normal and tangential inlets and outlets

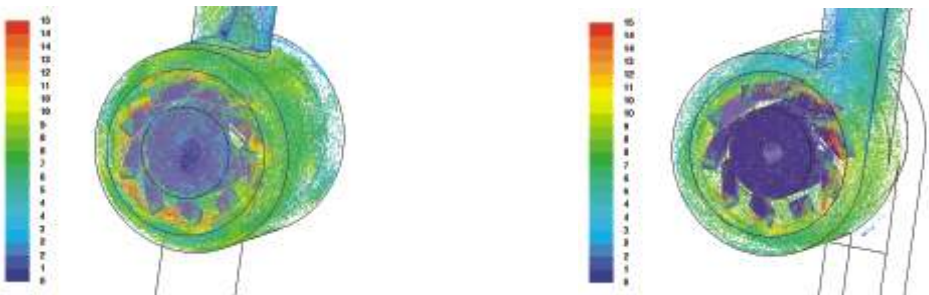

Fig.2: Particles coloured by velocity magnitude (m/s)



EDITORIAL IV | EXPERIMENTS

Dear Readers,

as our first CD-Labortatory came to an end by the end of 2015, also some experimental projects have been finalized over the last months and currently the overall results are being documented.

Bernhard König has concluded his PhD project within the previous K1Met funding period with some nice experiments to quantify slag entrainment.

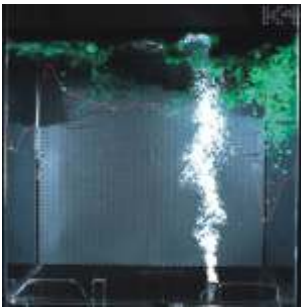

Fig.1: Entrainment of oil droplets in a three-phase lab experiment

With the end of the Dust-Recycling project located in the CDL, **Lukas Fiel** has managed to get our lab-scale feeding injection and pneumatic conveying system running in a closed loop mode, where the particles separated by the cyclone are directly shot back into the wind tunnel.



Fig.2: Cyclone with attached particle feeding injector to operate a closed loop dust recycling system

The cooperation with the Institute of Electrical Measurement and Measurement Signal Processing at the Technical University Graz comes to its final phase and we are currently work on an ECT field sensor to be installed in the pulverized coal conveying pipe at voestalpine in Linz.

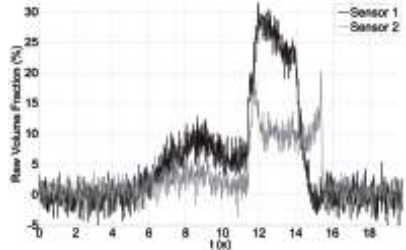
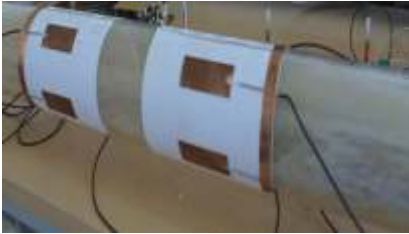
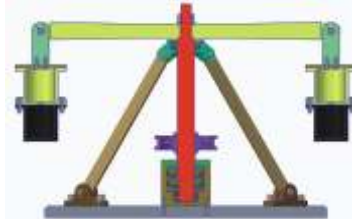

Fig.3: ECT

Florian Meier designed and built up a centrifuge test rig to investigate particle discharge from a cylindrical hopper under high gravity conditions. The first tests showed good agreement with the Beverloo equation.



Last but not least **Mathias Fleischer** has finished his first year at PFM and proved as a valuable member of our team. He is a big support for all people working in the laboratory!

2016 brings the start of some new long term projects within K1Met and Simon's CD-Lab. So it's time to grab a piece of paper and invent some new experiments from scratch...

Sincerely,



EXPERIMENTS | BUBBLE STIRRED FLOWS

Bubble stirred flows or bubbling beds are commonly known for several industrial processes in multiple fields for diverse purposes (e.g. thermal and species homogenisation).

However, the research done within this work is based on the steel production, where the hot metal desulfurization represents the main background. This process is a major step in refining hot metal and is executed as part of the converter process or within the ladle. By stirring the liquid metal utilising the upward movement of introduced bubbles the melt is homogenised and impurities are transported towards and accumulated within a buoyant slag layer. This induced turbulent flow is a key parameter for increasing the efficiency of mixture while reducing negative effects like wall-erosion. The approach to enhance the performance is the use of two spatially separated porous plugs which are alternately activated. The sensitivities of this activation time (AT) on the mixture, erosion, slag entrainment, and open-eye size represents the main focus of this work.

For experimental analysis the hot metal, the introduced stirring gas, and the overlaying slag are commonly substituted by a 'cold' system composed of water, pressurized air and a dedicated slag analogon (for example oil). This enables the usage of optical measurement techniques like Particle Image Velocimetry (PIV) aso. The realised setup is illustrated in Fig.1. The acquired data and analyses are dedicated to serve as a validation basis for novel CFD models.

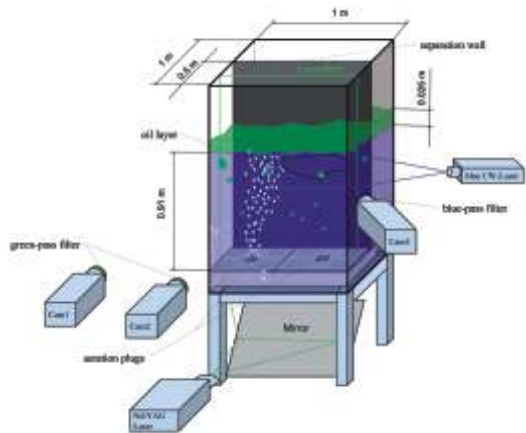

Fig.1: Experimental setup with optical discrimination of multiscale image acquisition

Therefore, the following achievements were successfully fulfilled and the sensitivities to the AT and gas-rates analysed:

- Development of a mathematical model for calculating a mixture potential based solely on 2d PIV data to avoid the cumbersome adding of a tracer phase.
- Refractory erosion estimations.
- Analyses of turbulent parameters like Kolmogorov slopes, vortex tracking, surface vortex intensity studies, etc.
- Development of image processing schemes to analyse the oil entrainment into the basin like exemplarily illustrated in Fig.2.
- Measurements of the open-eye area and parameters of operation to minimise its size (c.f. Fig.3).
- The development of an analyses software (TurbAn) which combines all processing steps for experimental as well as CFD data. This ensures best validation quality while providing fast and easy visualisation and data interpretation support.

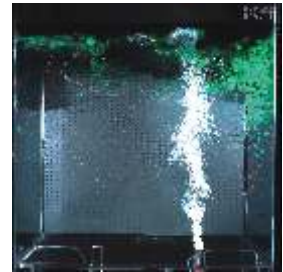

Fig.2: Slag entrainment test case with the entrained oil coloured green and the estimated envelope spline in red.

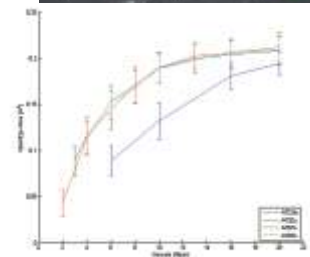
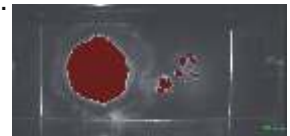

Fig.3: (Top image) Top view of the vessel for open eye detection (red).(Bottom image) Dependency of the open eye area on gas-rate and aeration time (AT)



EXPERIMENTS | PARTICULATE FLOW UNDER CENTRIFUGAL FORCE

Beverloo equation is maybe the most famous correlation to predict discharge rate in flat bottom hoppers. It has the following form:

$$Q = C \rho_b \sqrt{g(L - kd)^{5/2}}$$

where Q is the mass flow rate, ρ_b is the bulk density, g is the gravitational force, L is the outlet size, d is the particle diameter and C and k are constants. A few parameters are controlled in this equation and the gravitational force is the one we are interested.

By artificially increasing gravitational force we expected to increase mass flow of particulate material in the order of . Increasing the weight force of particles are also expected to break force chains formed among particles and turn commonly non-flowable material (highly cohesive) into flowable ones. Previous numerical studies shows positive results towards our predictions.

To validate our numerical models we assembled a centrifuge for accelerations up to 100g (Fig.1). Two cylinders are filled with the particles under testing. These cylinders are separated into two vertical sections by a flat plate with a hole initially closed. Rotations of up to 400 rpm are applied and a remote controlled device opens a hole allowing the material to flow (Fig. 2).

Besides the mechanical difficulties of building a structure that can withstand centrifugal forces beyond 1000kg (Fig.3), the opening and closing mechanism was a particular challenge. We needed the orifice to be open for a well defined period of time so we could calculate the mass flow from the total mass in the lower section. This remote controlled mechanism had to be as fast as possible not to interfere in the results as well as working reliable under increased friction conditions. We decided for a spring-loaded slide mechanism which is released and stopped by battery-powered electromagnets.

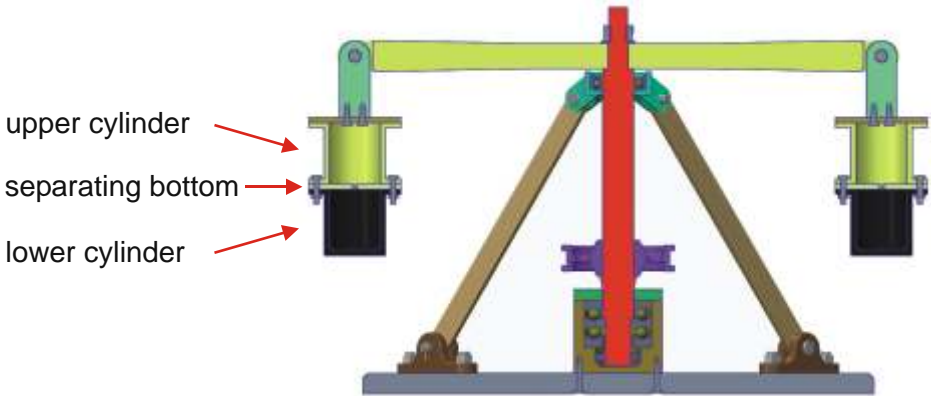

Fig.1: CAD model of the centrifuge. Details of material compartment.

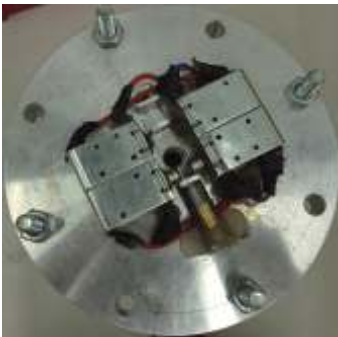

Fig.2: Details of the opening mechanism.



Fig.3: Basic setup of the centrifuge.

Florian Meier | Daniel Schiochet Nasato



EXPERIMENTS | BLAST FURNACE RACEWAY MEASUREMENTS AND DATA ANALYSIS

Previous activities have demonstrated the abilities to produce high quality image data from the raceway region of a blast furnace.

In Project 2.1 of the new K1Met funding period we are going to combine this visual data with other measurement data from the blast furnace and the pneumatic conveying installations of fuel substitutes (like pulverized coal).

In a first step we develop a data processing algorithm which detects dips in the hot wind throughput from the tuyere pressure signals (Fig.2). We expect these dips to correlate with raceway anomalies like blocking conditions or birds nest effects (Fig.1).

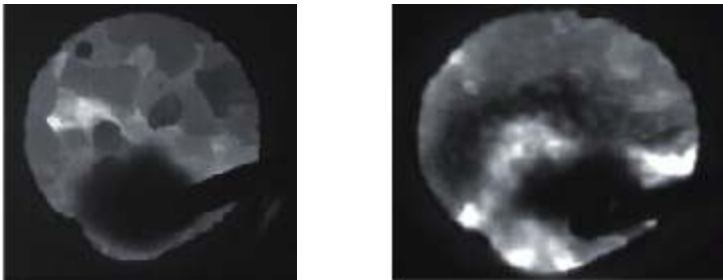

Fig.1: Raceway area as seen by a high-speed camera. The left side shows normal operation, on the right a big chunk of coke is blocking the tuyere.

The goal is to derive trigger signals from these pressure dips to start e.g. image recording from cameras installed on the tuyere spy glasses. With such an installation it would be possible to get a better understanding of such disturbances and define adequate action for efficient blast furnace operation (e.g. shutdown of fuel substitute input).

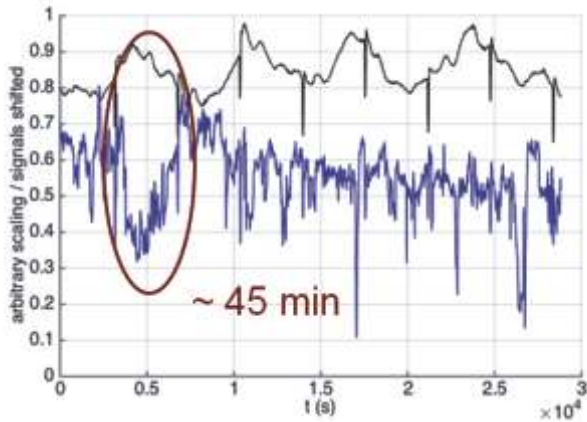

Fig.2: Tuyere pressure signal blue and cowper signal (black).

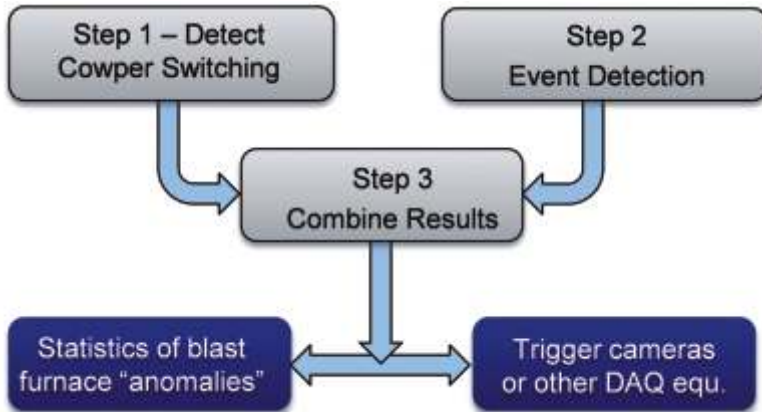

Fig.3: Flow chart of detection algorithm.



EXPERIMENTS | CLOSED LOOP DUST RECYCLING

Particle injectors are widely used in industrial applications to feed particles into pneumatic conveying pipelines. Over the last two years a huge parameter study has been conducted to collect validation data for CFD simulations and a 1D engineering tool. During this parameter study the test rig was used in a batch mode and the injector box was fed by a vibrating chute.

In a last step in this project the particle feeding injector was connected to our particle wind tunnel facility and run in a closed loop setup (Fig. 1). Cyclone 1 separates the particles into the feeding injector (yellow). They are then shot back via a 32mm conveying line into the main wind tunnel.

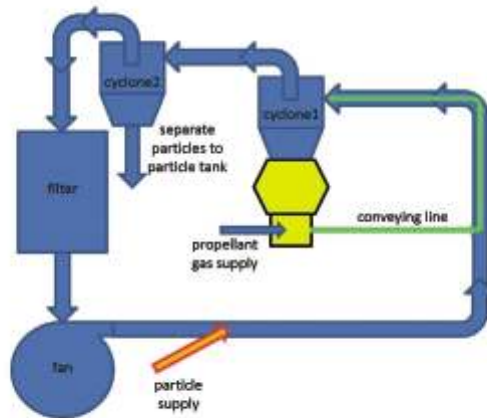

Fig.1: Closed loop setup of the lab test rig.

The crucial part in such a configuration is that the injector has to move the particles against an increasing pressure gradient, as the static pressure in the wind tunnel is higher than in the injector box at the cyclone outlet.

The whole setup turned out to work very reliable and run in quasi-steady state conditions for about 15min. After some time too many particles have left the closed loop as they were not separated by cyclone 1 and new particles need to be injected into the wind tunnel.



Fig.2: Nozzle and conveying duct of the feeding injector



Fig.3: Nozzle and conveying duct of the feeding injector



EXPERIMENTS | PARTICLE MOVEMENT IN A REDUCTION SHAFT

In the reduction shaft of a COREX plant a gas mixture is injected via two pipes located in the shaft with a certain distance in-between (see Fig.1).

While the bed of particles in the duct is descending bridging can happen near those pipes due to the occurrence of force chains in the granular material. Therefore the particle flow is locally prohibited and the efficiency of the reduction process decreases.

An experiment was designed to simulate, observe and measure the abovementioned phenomenon. Figures 2 and 3 show the outline of the lab-scale experiment.

The particles moving through the main shaft fall into the bottom container with a certain massflow \dot{m}_{out} . As soon as a certain mass level in the bottom container is reached the middle valve closes and the upper valve opens thus particles from the bottom container are being sucked up into the buffer hopper with a massflow of \dot{m}_{up} . The bottom container is now losing weight because \dot{m}_{up} is bigger than \dot{m}_{out} and will return to its original total weight. When this happens the upper valve closes and the middle one opens again. The buffer gets emptied and the main duct gets almost instantly refilled now. The cycle starts anew and a more or less constant mass flow through the main duct is being sustained.

Bridging can now be „measured“ with a front camera. After postprocessing the gathered videos or images can give insight to what exactly happens when force chains are emerging.

If used in batch mode (no particle feedback), the remaining bridges can be captured and quantified from above (Fig.4).

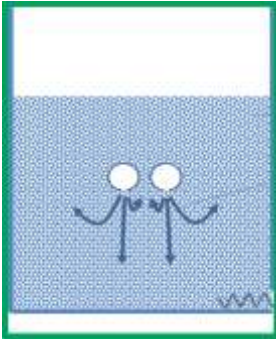

Fig.1: Schematic of a reduction shaft

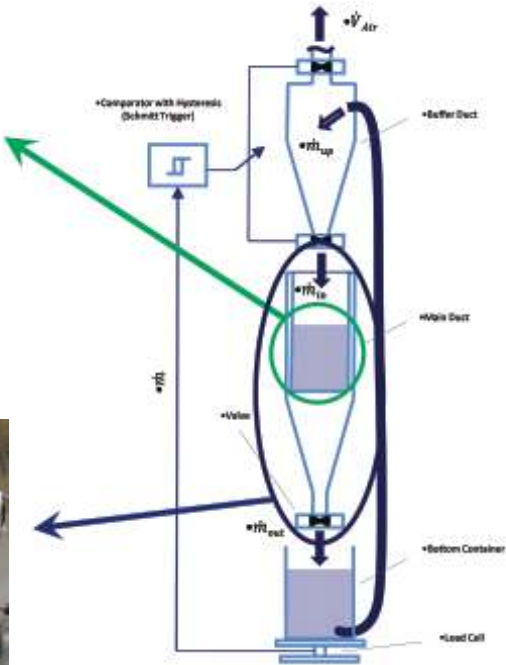

Fig.2: Design layout of experiment

Fig.3: Main duct with gas pipes and two camera setups

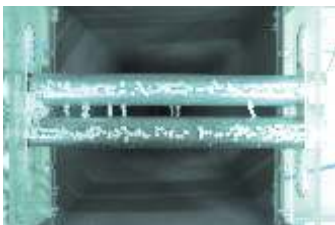

Fig.4: Bridges after a complete removal of Particles.



EXPERIMENTS | ELECTRICAL CAPACITANCE TOMOGRAPHY

In 2015 we continued our collaboration with the Institute of Electrical Measurement and Measurement Signal Processing (EMT) at Graz University of Technology. Markus Neumayer, Matthias Flatscher and Thomas Bretterkieber of EMT develop methods and hardware for Electrical Capacitance Tomography (ECT) for flow imaging in our lab.

Figure 1 illustrates a flow imaging experiment in a vertical pipe at a test rig in Graz. The particle stream is manipulated to be non centric. By means of an ECT sensor (red circle in figure 1) and dedicated signal processing methods the lower image can be computed, where the spatial concentration of the stream is visualized.

For the determination of temporal/spatial information of flows in pneumatic conveying (e.g. flow regimes), EMT works on twin plane ECT systems as depicted in Fig.2. In this experiment a PVC plug was pushed through the pipe. The plug can be visualized by means of consecutive slice plots.

Figure 3 illustrates the reconstruction of a non stationary granular flow. Beside slice plots, measures like volume fraction estimates can be computed to analyse the behaviour of the flow. Thus, ECT allows for a instantaneous extraction of information about the flow, which cannot be done by means of traditional measurements.

Currently EMT finalizes the developments to install them to our lab facility.

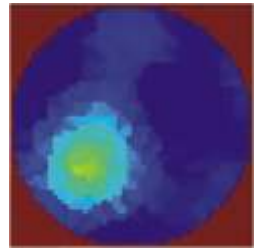

Fig. 1: ECT Imaging of granular flow in a vertical pipe.



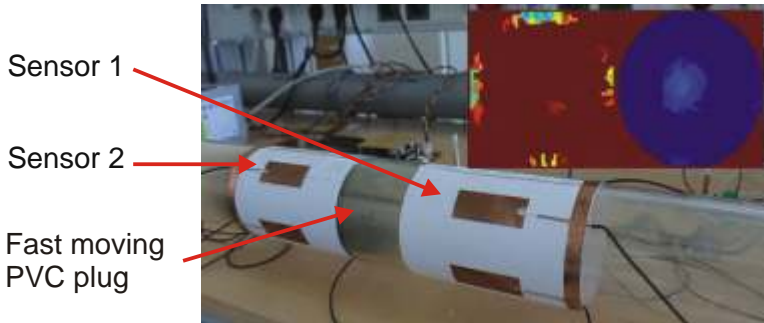

Fig.2: Twin plane ECT sensor at EMT test rig and reconstruction of fast moving plastic plug.

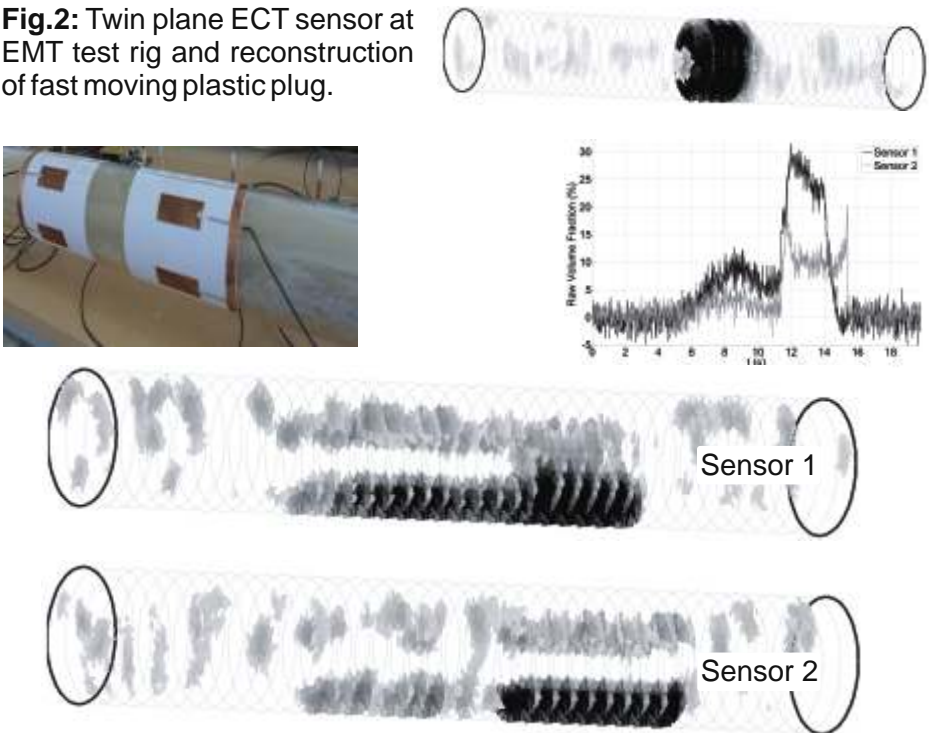

Fig.3: Pneumatic conveying experiment and reconstruction results for a nonstationary flow. Slice plots and volume fraction estimates can be used to characterize the present flow regime.

SCIENTIFIC FRIENDS | T. NAJUCH & J. SUN & P. SEIL, THE UNIVERSITY OF EDINBURGH & JKU

The rheology of dense suspensions is complex and has not been fully understood yet. In one of our projects in Edinburgh, we are, for instance, interested in unsteady phenomena in suspensions, such as shear reversal and their implications on macroscopic models. To this end, high-fidelity simulations fully resolving the fluid motion are required.

One of our collaborating partners, DCS Computing, pointed out the exciting LBDEM coupling project at the JKU and after comparison with similar software, we opted for the LBDEM coupling due to the high likelihood of being able to carry out simulations of dense suspensions.

Extensive testing in terms of code capabilities and physical verification of the software was mandatory for us. During the testing process, we discovered inconsistencies which were rectified in close collaboration with Philippe Seil, the main developer of LBDEMcoupling. The outcome is an improved code with additional undertaken verification.

One specific example is the implementation of lubrication force model. In dense suspensions, lubrication forces affect strongly the macroscopic behaviour. Close contact behaviour of two approaching particles (Fig.1) has been studied in detail. It is possible to resolve the lubrication forces down to the limit of one lattice cell in between the particles. For smaller gap distances, a lubrication force correction has to be applied. A lubrication force correction proposed in literature [1] was implemented, but with the fluid-solid coupling methodology used in the LBDEM code, the results are not satisfactory (Fig.2).

However, based on the characteristics of the fluid-solid coupling methodology, we proposed an improved normal lubrication force correction which yields accurate results (Fig.3).

[1] Nguyen and Ladd, Physical Review E 66, 046708 (2002)

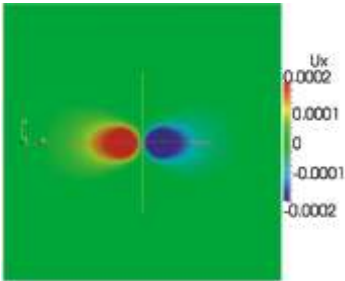

Fig.1 (left): Fluid velocity around two approaching monosized particles with the same constant velocity ($Re = 0.1$)

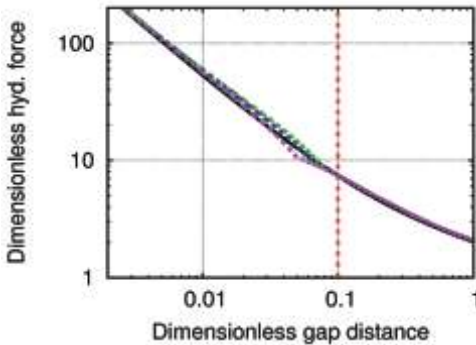

Fig.2 (left): Hydrodynamic force with applied lubrication force correction [1] is plotted against particle gap distance. Black line: analytical solution. Coloured lines: Simulations with different cut-off distances. Red vertical line: Gap distance of one lattice spacing in between the particles

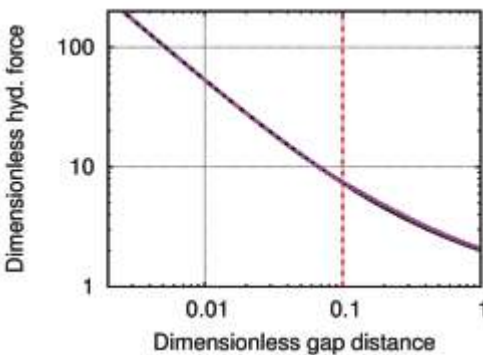

Fig.3 (top): Same as Fig.2, but with our proposed lubrication force correction (magenta line)



SCIENTIFIC FRIENDS |

ALEXANDER PODLOZHNYUK, T-MAPPP EARLY STAGE RESEARCHER, DCS COMPUTING GMBH

Particle shape representation is a fundamental problem in the Discrete Element Method (DEM). Spheres remain popular in DEM codes due to their simplicity in terms of implementation and computational time. However, in real life particles are mostly non-spherical and particle shape significantly influences on mechanical properties of granular flows. Moreover, spheres represent different mechanical behaviour with comparison to real particles even on a single grain level. Therefore, non-spherical shape models need to be introduced in DEM.

Several methods were proposed in literature to handle particle non-sphericity in DEM. These include multispheres (glued spheres), spherocylinders (capsules), polyhedral particles and ellipsoids. One of the non-spherical shape models are so called superquadrics (or super-ellipsoids) that show trade-off between shape flexibility and shape complexity. This shape model was successfully implemented in the open-source DEM code LIGGGHTS®, including particle-particle, particle-wall, particle-triangle contact detection and contact force calculation algorithms. To simplify, superquadric shape is a generalization of spherical and ellipsoidal shapes that gives an opportunity to switch from a spherical to a cylindrical or box-like particle varying only 5 shape parameters. Figure 1 (left) shows examples of real particles (sugar cube, candy, chewing gum), Fig.1 (right) shows their approximation by superquadrics.



Fig.1: Examples of real particles (left) and their approximation by superquadrics (right).

The superquadric DEM code was validated on several test cases such as angle of repose, hopper discharge and rotating drum. Results demonstrate robustness of the implemented algorithms, good quantitative and qualitative agreement with experiments.

Future efforts will be concentrated on optimization of the contact detection algorithm and coupling with CFD solvers.



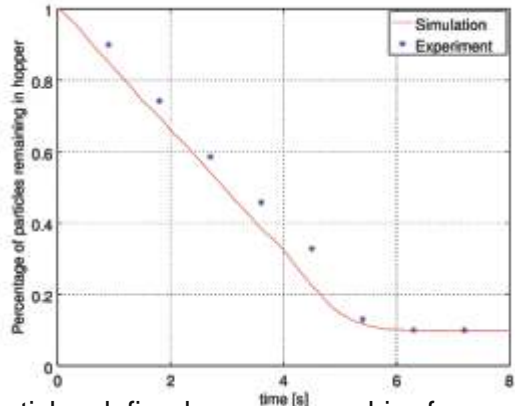
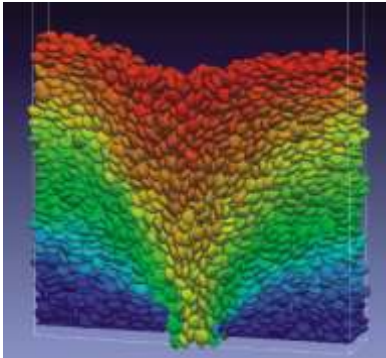

Fig.2: Discharge of ellipsoidal particles defined as superquadrics from a hopper. Screenshot of the simulation (left) and percentage of particles remaining in the hopper as function of time (right).

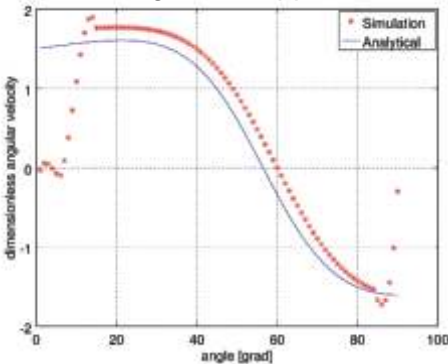

Fig.3: Dimensionless post-impact angular velocity ($r\omega_y/v_{imp}$) of a cylindrical (defined as superquadric) particle as function of impact angle

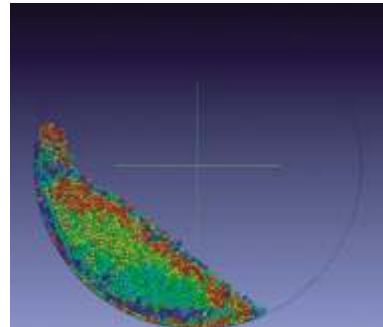

Fig.4: Rotating drum

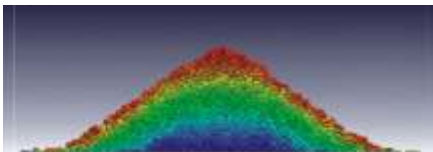

Fig.5: Angle of repose



SEMINAR | AEROSOLS DISPERSION

In this this years seminar we decided to continue to work on the topic of aerosols dispersion, which has a great impact on society. Last years seminar focused on the development of a cheap aerosol swarm measurement device yielding data for the particels in the PM10 and PM2.5 classes. Such a swarm of dust measurement units (DMUs) should send their data to a central data server for further processes (compare with Fig.3).

This year we deal with the numerical simulation of aerosols dispersion. Here, on the one hand the question arises how we can use the detailed information of the DMUs to detect potential emitters. On the other hand, a numerically efficient method is required to predict the dispersion of aerosols from potential emitters based on the local wind conditions (Fig.1).

The first aim is a so called inverse problem, where the solution of the forward dispersion of the aerosols is known at certain positions while the emitters are unknown. By using reversed time marching methods (RTMM) we intend to integrate the transport equations for the aerosols dispersion backward in time to obtain the location as well as the amount of potential emissions (Fig.2).

The second problem is addressed by using recurrence CFD (rCFD; compare also with the contribution on page 25. Unsteady flows are mostly characterized by recurring flow patterns. In the course of conventional CFD simulations we can identify such characteristic flow features and subsequently stitch them together to form generic unsteady wind fields by applying statistical reasoning and introducing a certain degree of randomness. Such an approach will lead to a numerically efficient analysis of the local wind situation, which can be used to study aerosols dispersion.

Finally, the outcome of this years seminar should yield to a research project together with local authorities to make on the one hand, the DMUs available for the public and on the other hand, to improve the numerical prediction of urban pollutants dispersion.

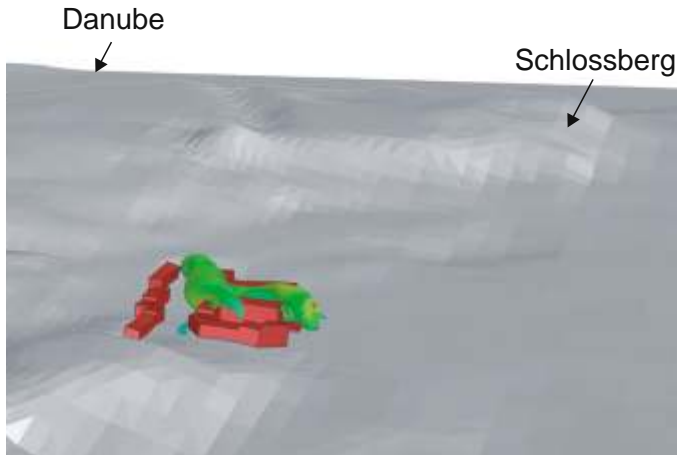

Fig.1: Virtual scenario of dust emissions coming from the Römerbergtunnel.

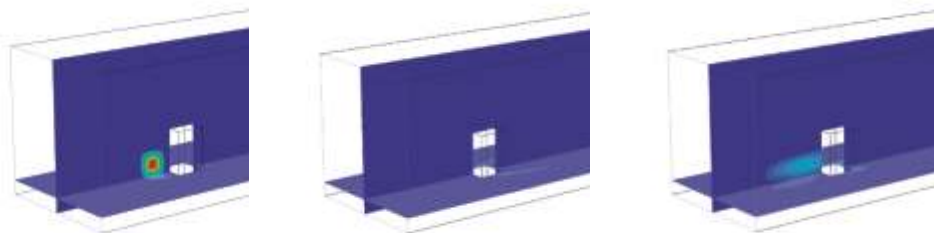

Fig.2: left: initial concentration of emissions; middle: dispersed pollutants; right: backward simulation result started from the situation in the middle by using RTMM.



Fig.3: Concept of a swarm of small autonomous dust measurement units for local emission or immission measurements



SELECTED PUBLICATION

Schneiderbauer S., Puttinger S., Pirker S., Aguayo P., Kanellopoulos V.: CFD Modeling and Simulation of Industrial Scale Olefin Polymerization Fluidized Bed Reactors, in: Chemical Engineering Journal, Volume 264, Page(s) 99-112, 2015.

Saeedipour M., Pirker S., Schneiderbauer S.: Numerical study on liquid jet breakup and droplet-wall interaction in High Pressure Die Casting process, in: Proc. of the ICLASS 2015, 13th Int. Conf. on Liquid Atomization and Spray Systems, 2015. (Awarded Publication)

Berger R., Kloss C., Kohlmeyer A., Pirker S.: Hybrid parallelization of the LIGGGHTS open-source DEM code, in: Powder Technology, Volume 278, Page(s) 234 - 247, 2015.

Soleimani A., Pirker S., Schneiderbauer S.: Solids boundary condition for collisional gas-solid flows at rough walls, in: Powder Technology, Volume in press, 2015.

Puttinger S., Schneiderbauer S., von Berg L., Pirker S.: Inhomogeneous Segregation of Binary Mixtures in Fluidized Beds, in: Procedia Engineering, 2015.

Benvenuti L., Kloss C., Pirker S.: DEM Particle Characterization by Artificial Neural Networks and Macroscopic Experiments, in: Particles 2015, 2015.

König B., Puttinger S., Pirker S.: Turbulent measurements within a gas stirred three-phase bubble column with multiple aeration plugs, in: CSM: Proc. of The 6th Int. Cong. on the Science and Technology of Steelmaking, Vol. 6, China Machine Press, 2015.

Schiochet Nasato D., Pirker S., Lichtenegger T., Kloss C.: Numerical simulation of porosity of cohesive powders after die filling process in dependence of different pouring and shaking recipes, in: Proc. of EURO PM 2015 Congress, 2015.

Seil P., Wierink G., Pirker S.: Multi-scale modelling of sedimentation onset in river beds, in: 11. Minisymposium Verfahrenstechnik, Proc., 2015.

Queteschner D., Lichtenegger T., Pirker S.: A versatile particle fragmentation model using the discrete element model, PARTICLES 2015 IV Int. I Conf. on Particle-Based Methods., Technical University of Catalonia (UPC) Barcelona, 2015.

Imprint:

DEPARTMENT OF PARTICULATE FLOW MODELLING

T +43 (0)732/2468 6477 | **F** +43 (0)732/2468 6462 | **W** <http://www.particulate-flow.at>

P | Altenbergerstrasse 69 | 4040 Linz | Austria

